

Tutorial-3 Room Expansion.

1. Open your saved project from Tutorial-2. It should look as shown below:

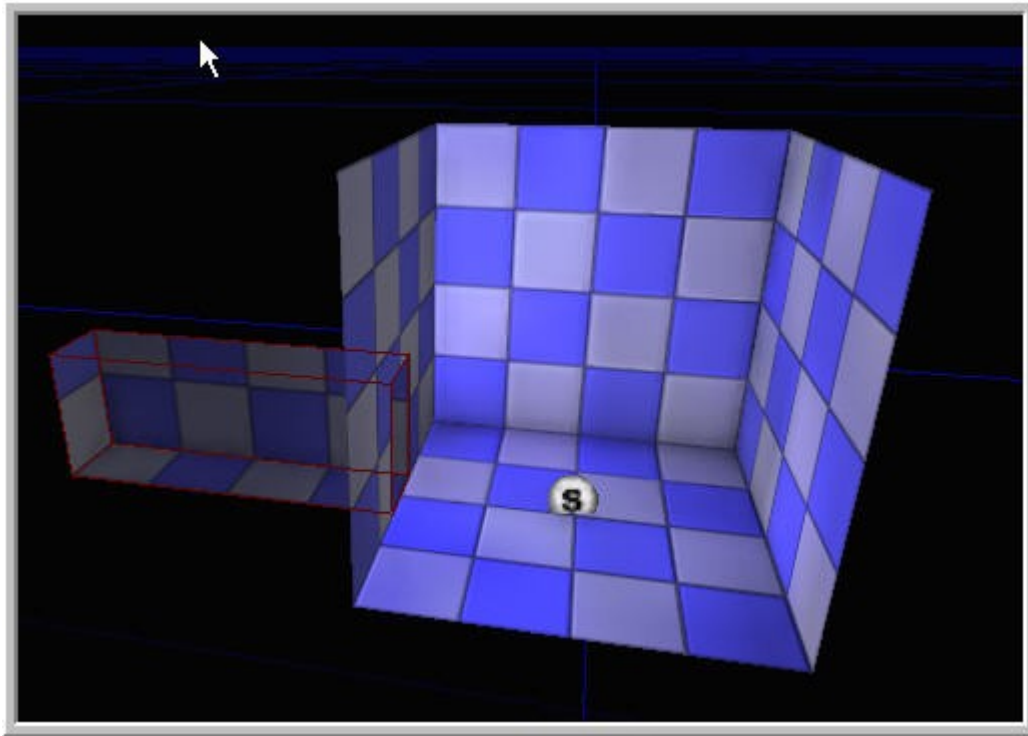

2. Click on the Brush wireframe button to get the wireframe view in the 3-D viewport. Highlight the hallway wireframe by clicking on it. This is the brush we will use to create our new larger room. See the figure below:

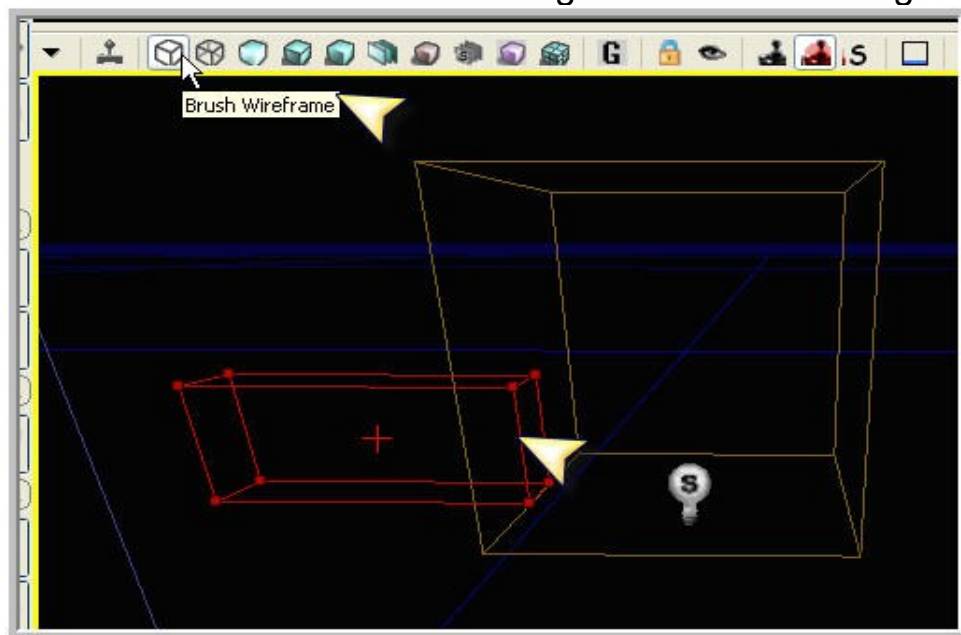

3. With the red wireframe brush highlighted, tap the spacebar to get the translation arrows as shown below:

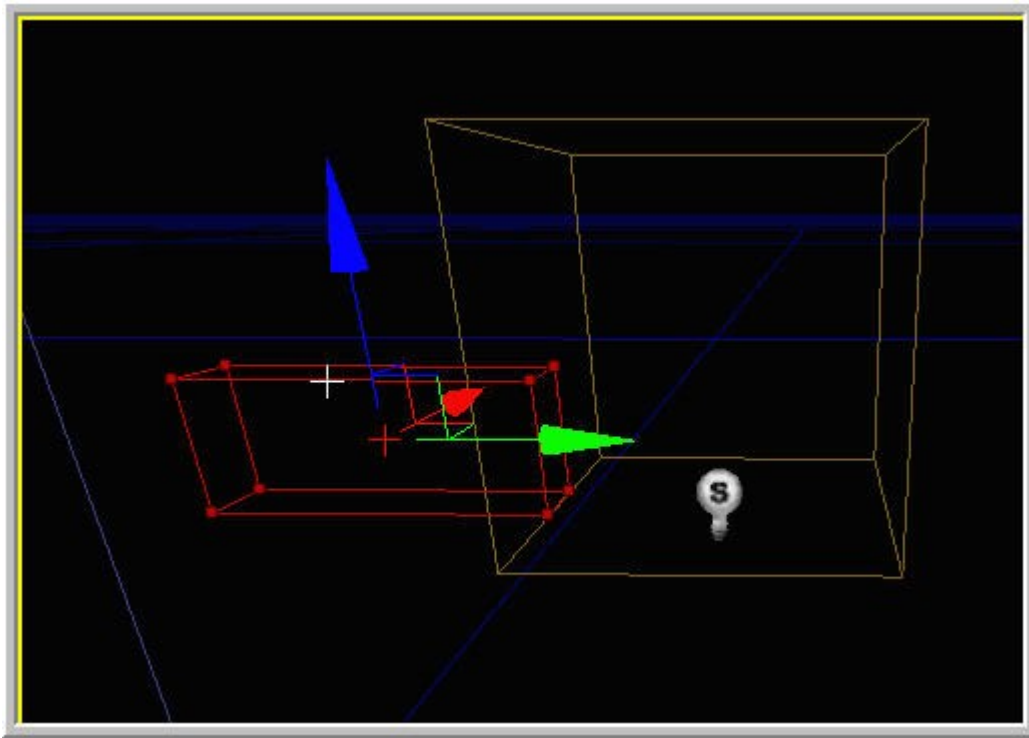

4. Select the Green translation arrow with the left mouse button and drag the red wireframe brush directly to the left as shown below:

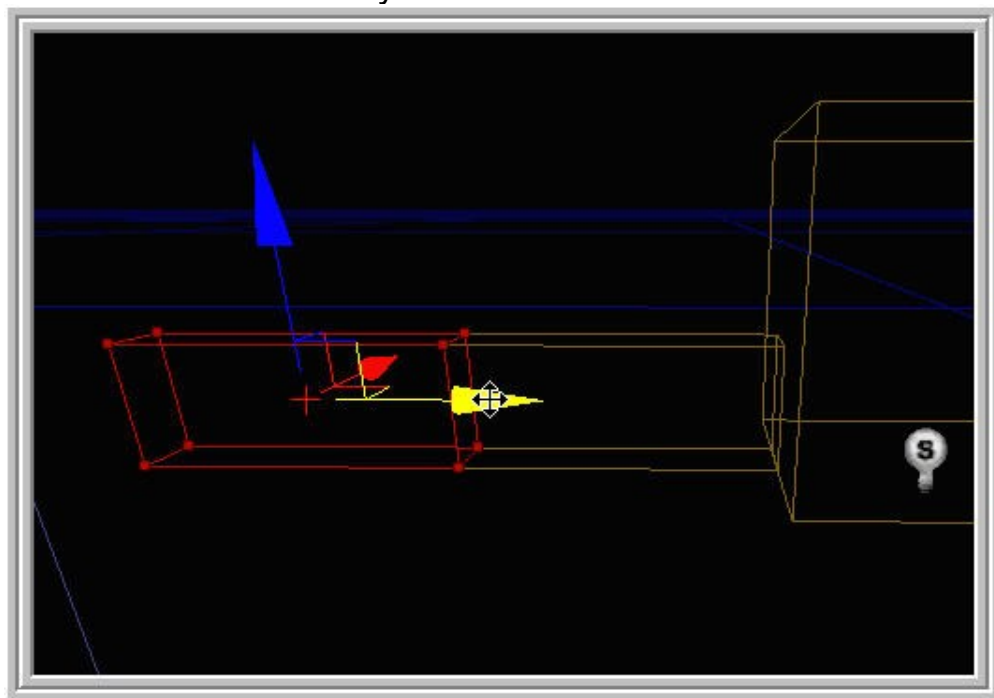

5. Next, tap the Spacebar until you get the Expansion Blocks as shown in the figure below:

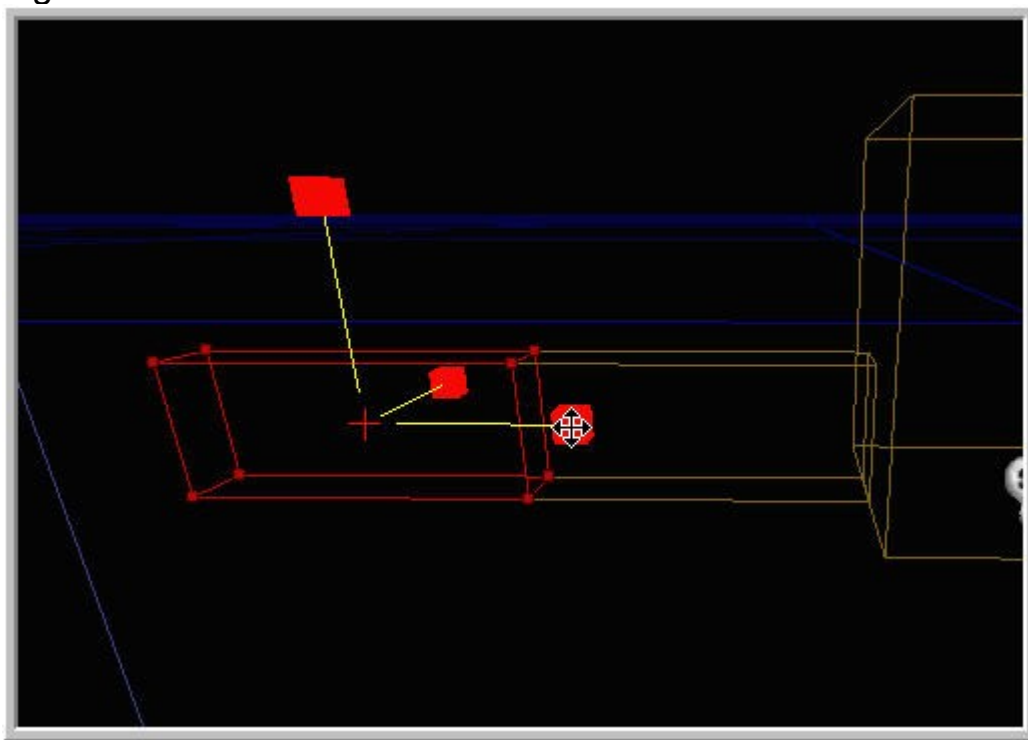

6. With the left mouse button held down, drag on one of the expansion blocks to expand the size of the brush as shown in the figure below:

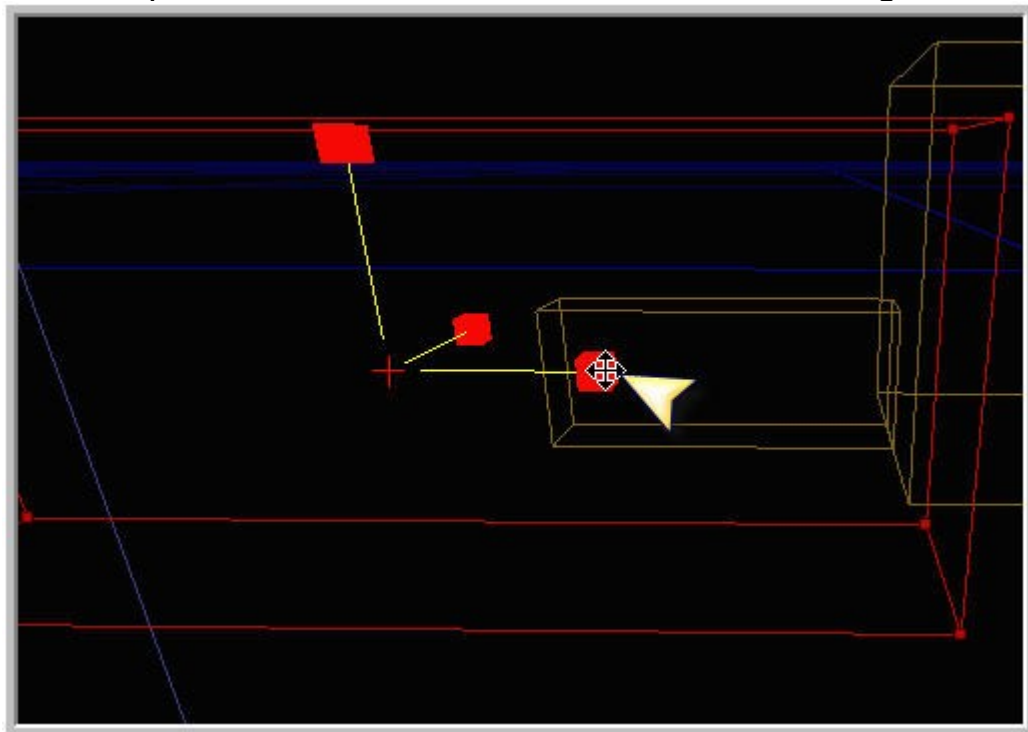

7. The exact size of this brush is not important just as long as it is close to what you see in the above figure.
8. Next, tapping on the Spacebar, use the Translation Arrows to align the expanded brush to the exact left and bottom of the hallway. Use the front view to do this as shown below:

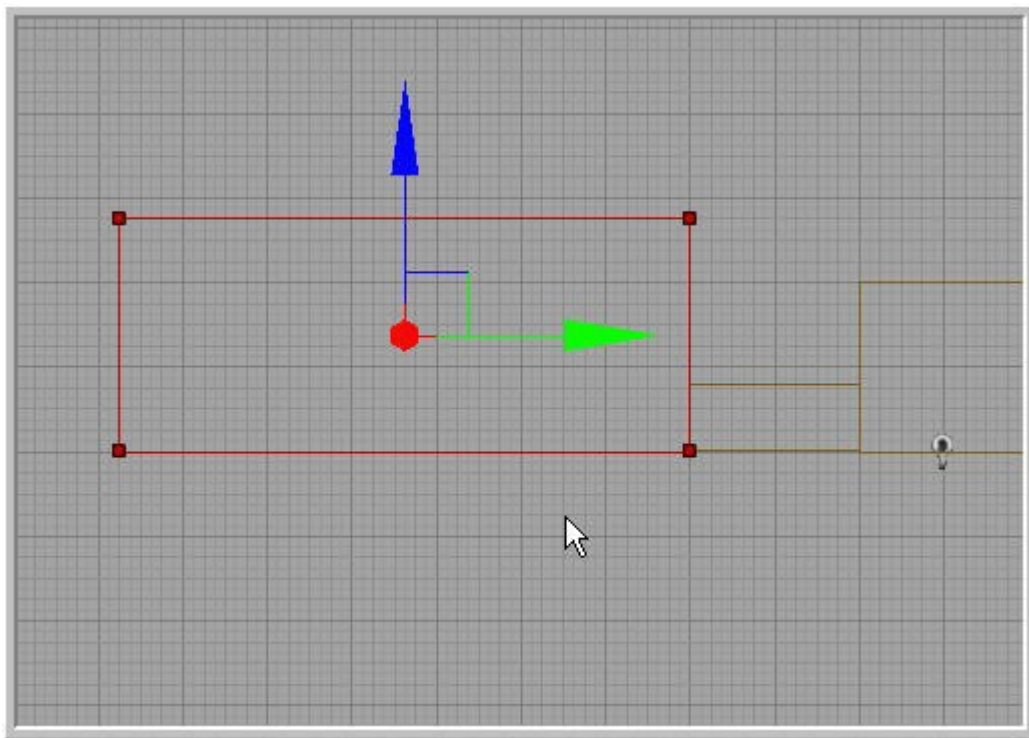

9. If the brushes floor and wall do not line up perfectly with the hallway, select the red wireframe brush then right-click to bring up the menu shown below. Select Snap Vertices to Grid. This will now adjust the vertices of the wireframe to the grid.

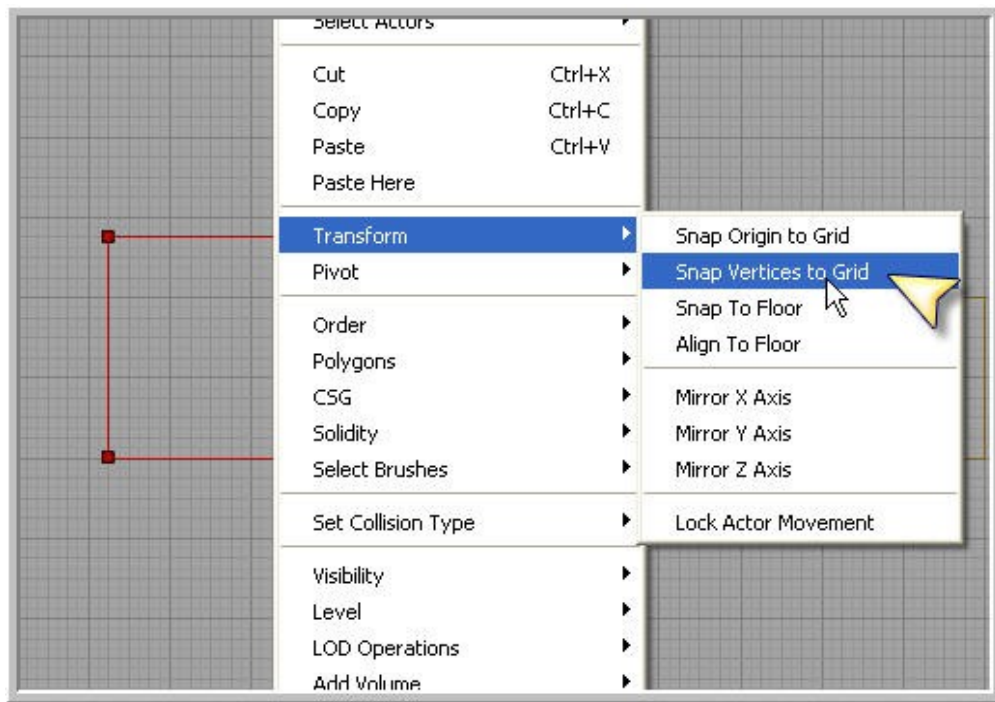

10. Go back to the 3-D view and select the Unlit button as shown below:

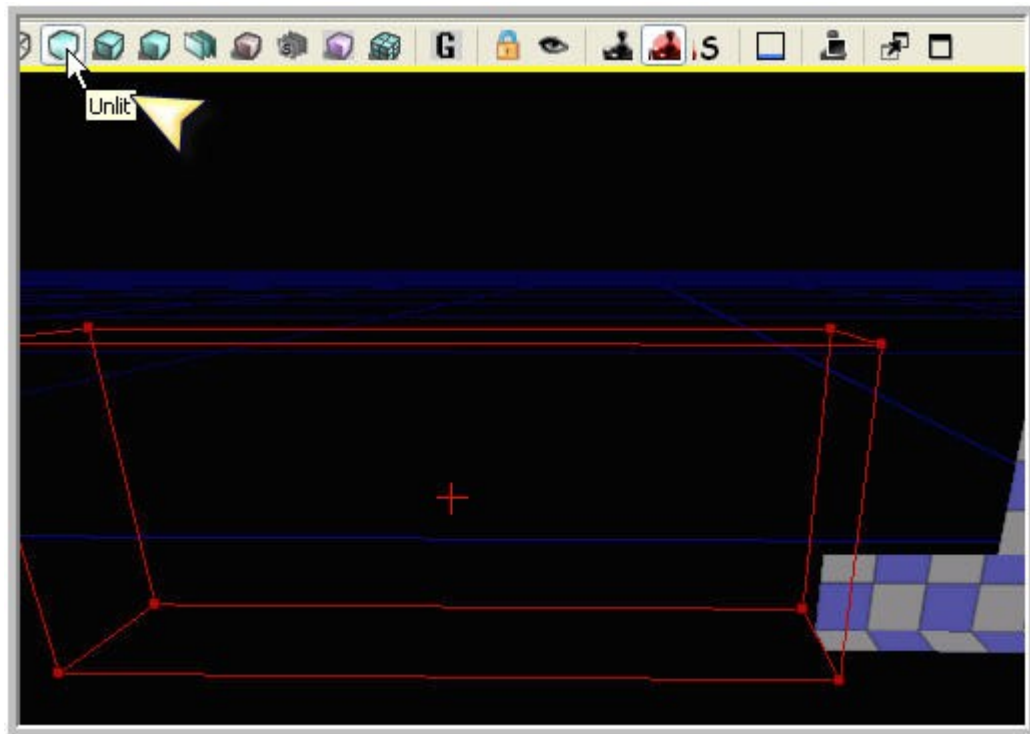

11. Next click on the CSG Subtract Button as shown below:

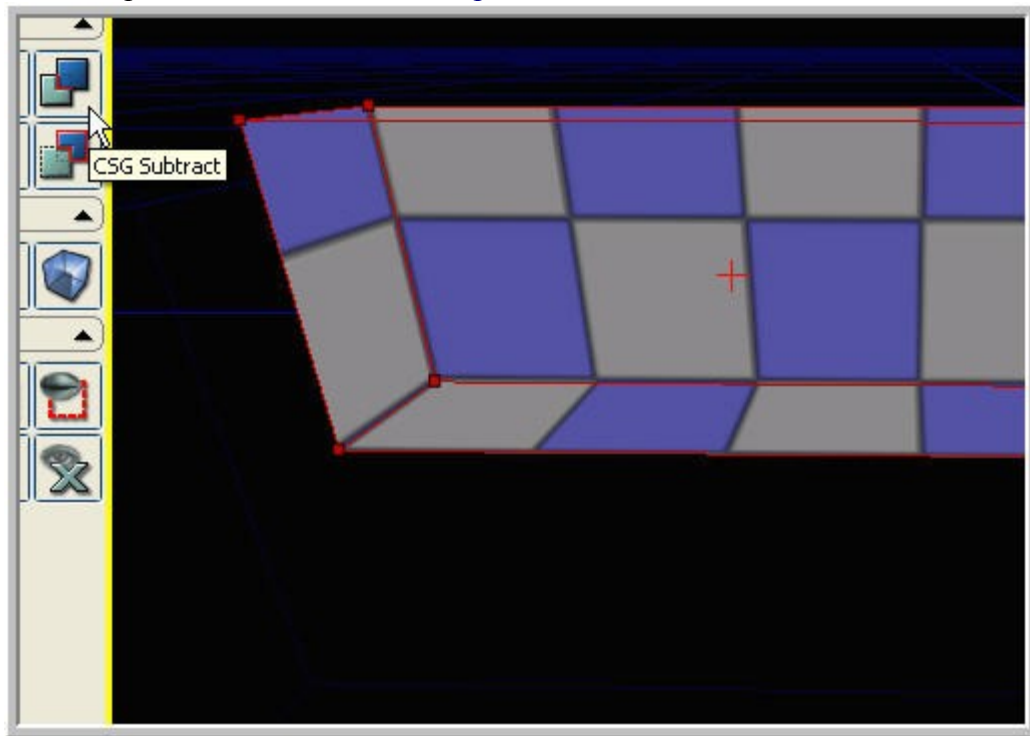

12. Add a light to your new room. See below:

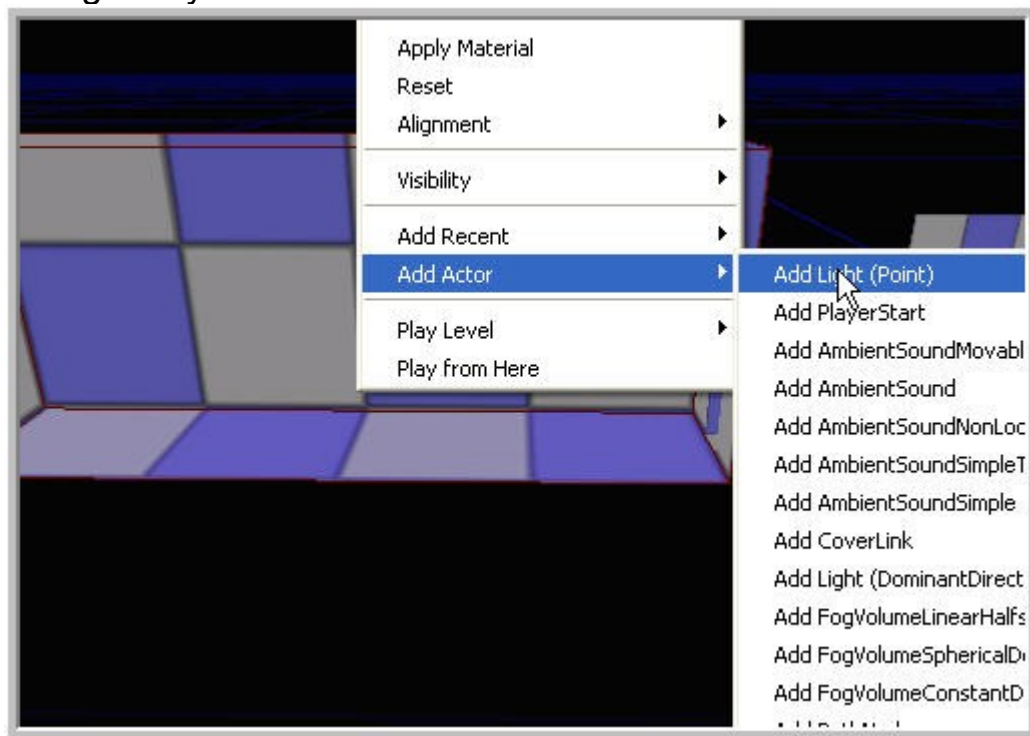

13. Next, click on the Lit button to see the effects of your light as shown below:

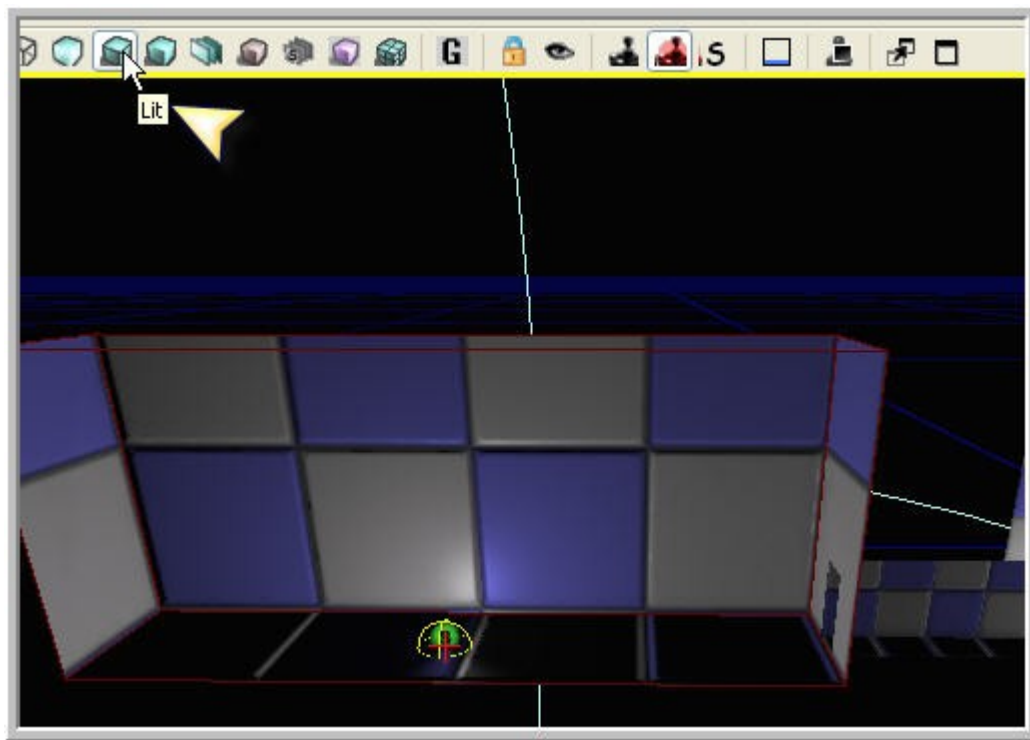

14. Now click on the BuildAll button as shown below:

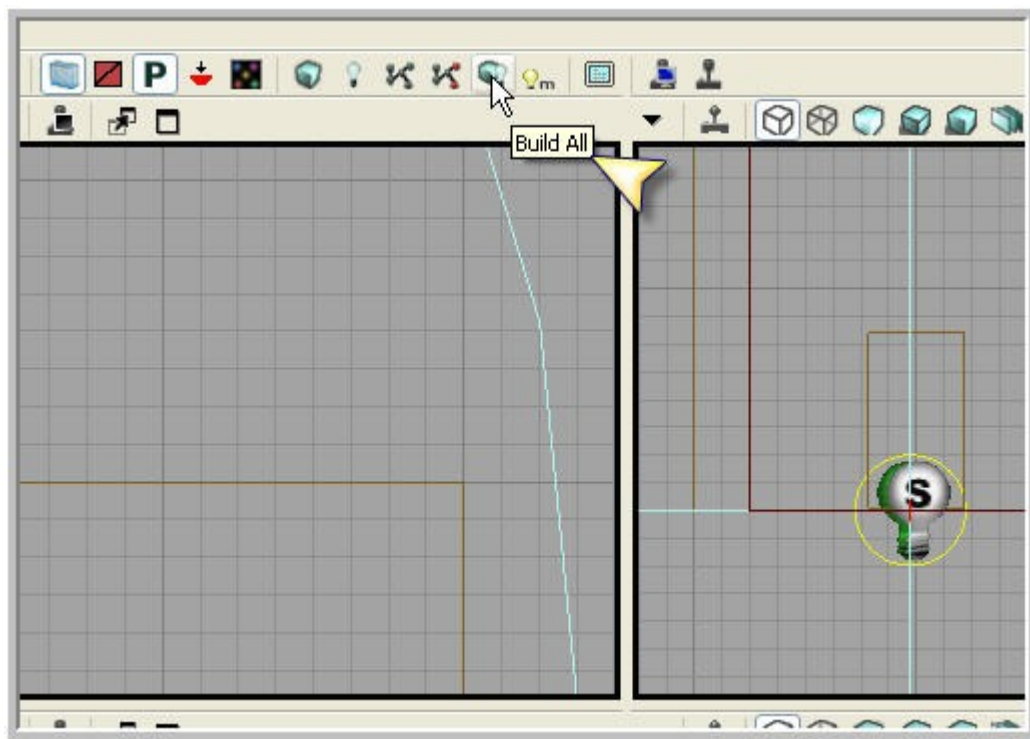

15. Next right click on the floor and select Play From Here as shown below:

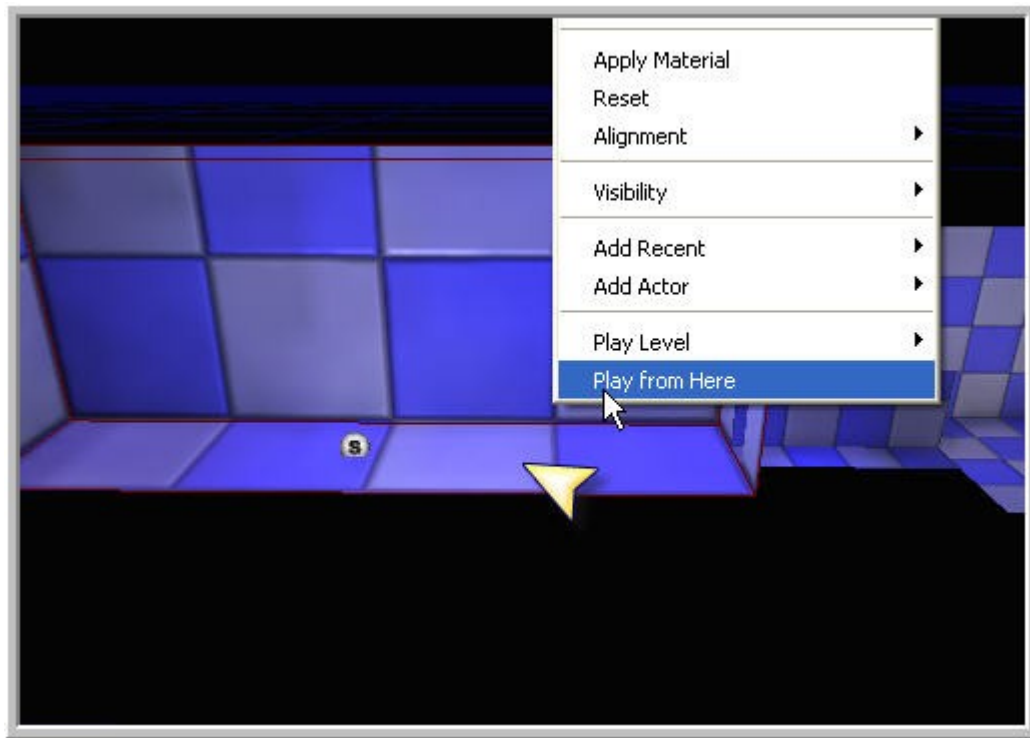

16. You can now walk through your new rooms.

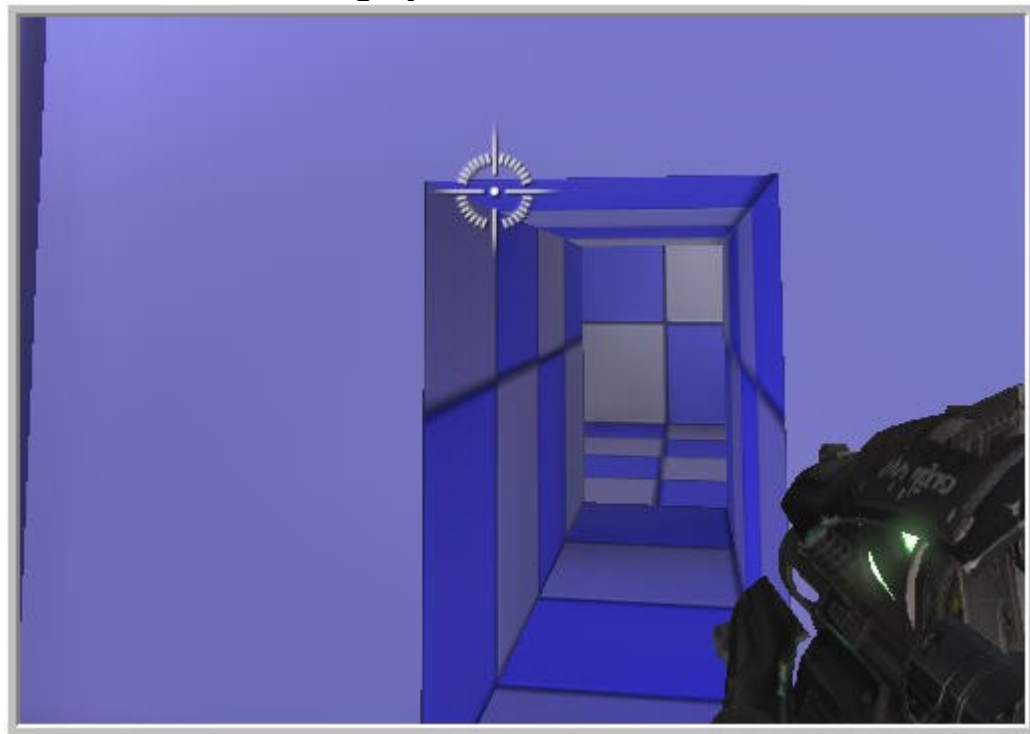

Save what you have done. The next tutorial will show how to add a shelf to your room.